



MESA DAY CONTEST RULES

Cargo Glider

LEVEL:	Middle School (MS)
COMPOSITION OF TEAM:	3-5 students per team
NUMBER OF TEAMS:	Regional – At most 3 teams per school MESA Day – 1 team per school

OVERVIEW: Students will design and construct a glider with a payload that, when launched by the Launching Mechanism, flies through the air, goes over an obstacle and lands the farthest. The glider must be the original work of each team. Judges may ask questions for verification. Students should take into consideration the transportation of projects; competition ready projects must be transported safely to the competition site.

An engineering poster is a required component of this competition. The purpose of the Poster is for students to better understand the process an engineer goes through in the creation of a project. MESA projects are not designed to be completed in a single class period or day, but to be the result of thoughtful research, planning, analysis and evaluation. Keeping a lab book throughout the design process will help to keep a designer on track, using a logical progression of planning, in order to develop their project efficiently.

RESOURCE VIDEOS: [Cargo Glider Competition Overview](#)
[Cargo Glider Concepts](#)
[Overhead How To Build A Glider](#)

MATERIALS: **LEGAL:** Various materials may be used to build the glider; materials are not limited to wood. Students should consider the strength of the material needed to withstand the force of the launcher. There is no restriction to the size and/or weight of the glider.

ILLEGAL:

- Hazardous materials (to be determined by the host center)
- Remote control devices of any kind
- Additional power source(s) (i.e., thrust, lift or stored energy that assists dynamic flight) may NOT be supplied.

For the Engineering Poster, electronic submission will be required. Teams should use an electronic portal/application such as Google Slides to keep and maintain their data. Posters will be turned in approximately two weeks before the competition.

The Host Center will provide the following:

- 2 six-foot tables for the impound station
- 1 six-foot table for the repair station
- 1 six-foot [COSCO folding table](#) or equivalent for Official Launcher Mechanism
- 5 ft PVC Pipe and T joint PVC Pipes to support the folding table ([LINK](#))
- Launcher will have a new rubber band after 70 uses with 15 initial uses to prime the rubber band.
- Safety goggles for team members and judge
- [3D Printed launcher adapter](#) (optional to use)

GENERAL RULES:

- 1) The students' full name, grade level, and school name MUST be clearly labeled on the glider. A 10% penalty in the score will be assessed for failing to properly label. Gliders checked-in with a tie-on label will be required to launch having the label tied on.
- 2) The glider MUST contain an easily identifiable, prominent feature on the fuselage that adapts and connects with the launcher adapter or rubber band. Failure to follow this rule will result in a 10% penalty.
- 3) Teams must be able to show the number of ping pong balls (i.e., cargo/payload) the glider contains to the judge during registration.
 - a. The glider MUST have two (2) ping pong balls as its cargo for all divisions/grades.
 - b. Teams cannot change the shape of the ping pong balls in any way, that includes crushing, cutting, drilling, etc.
 - c. Teams MUST use 1 star rated ping pong balls. [Examples](#)
 - d. Gluing or taping balls to the glider or each other is acceptable as long as teams can show the judges that balls have not been modified and the one star marking is visible.
- 4) Teams may only register/turn-in one glider for the competition.
- 5) All repair materials and tools MUST be provided by each team when registering at check-in. A toolkit provided by a school representative is permitted.

- 6) For the purpose of this competition, a glider is defined as a self-contained flying vehicle that remains intact during flight. The glider cannot have links of any kind with the ground that provide lift, propulsion or course guidance during the flight.
- 7) Glider parts that break off during LANDING (i.e., upon initial impact with the ground or any object) are permissible but are not encouraged.
- 8) If parts of the glider break off DURING flight (i.e., while in flight) including the ping pong balls (i.e., cargo/payload), the launch is considered a MISTRIAL. Flights that result in a mistrial are NOT eligible for points.
- 9) The glider MUST fly over the 60-inch (152.40 cm) obstacle and MUST stay within the 10-foot (3.048 m) width of the obstacle. For gliders that go outside this boundary or make contact with the obstacle, the launch is considered a MISTRIAL." ([see Attachment C: Obstacle Specification](#))
 - a. If both launches are a MISTRIAL, the score will not be recorded.
- 10) The glider can be made from VARIOUS MATERIALS and have no restrictions on size or weight, however the glider MUST be capable of being launched by the official launcher and MUST have an identifiable fuselage, wing, and tail.
- 11) Remote-control (electronic) devices of any kind may not be used. If mechanical devices are used, these devices must be self-contained and may not provide any thrust to the glider.
- 12) Additional power source(s) (i.e., thrust, lift or stored energy that assists dynamic flight) may NOT be supplied. The only power source allowed is the official glider launcher.
- 13) The judges' decision regarding the location of the glider's first-touch point (i.e., landing location) is considered final and is not subject for debate. Digital media (e.g., photos, video recordings, etc.) will not be accepted.
- 14) Only team members can hold and repair their glider. The impound and repair station areas will be supervised by competition judges. Advisors, guardians, parents, and/or teachers are not allowed in the designated impound/ repair areas.

JUDGING:

- 1) Gliders will be checked for specifications prior to the start of the competition. Teams that do not meet specifications after this initial check will have an opportunity to compete if they meet ALL of the following conditions:
 - a. Accept an automatic "Mistrial" and therefore no score for Launch #1.
 - b. Make repairs/modifications as necessary to bring the glider to proper specifications and be ready to compete when called for Launch #2.
 - c. Make repairs/modifications only in the designated area as indicated by the judges.
 - d. Failure to adhere to any of a, b, or c will result in disqualification.
- 2) Teams that meet the specification check but wish to make repairs and modifications may do so, but they MUST be ready to compete when called for Launch #1.
- 3) Each team will be allowed two (2) non-consecutive launches for their glider.
- 4) Each team MUST be ready and report to a judge within 1 minute of being called to launch their glider. Failure to report within 1 minute of being called will result in a forfeited trial/launch.
- 5) Each team will be given a 1-minute window to set-up and then launch their glider.

- 6) The Rubber Band of the Official Launcher Mechanism **MUST** not be pulled back more than 36in (91.44 cm) from the edge of the launching mechanism to be considered a successful launch.
- 7) The glider's first-touch point (contact with any object) will be marked by the judges.
- 8) Measurements will be taken perpendicular to the launching mechanism and the glider's first-touch point. Measurements will be to the nearest 2 cm (0.75 inches).
- 9) The decision of the judges on the location of the first-touch point is final and not up for debate.
- 10) Teams are responsible for removing their glider from the contest area immediately after judges have marked the first-touch point.
- 11) One member of each team will be asked to place their glider on the impound table (an area designated by the judges) or the repair station table after every trial.
- 12) All glider repairs and/or alterations **MUST** be made under the supervision of a judge. New/spare/replacement parts **ARE NOT ALLOWED**. Repairs or alterations can **ONLY** be made with parts originally used when the glider was submitted for specification checks. Glue and/or tape to affix broken pieces is **ALLOWED**.
- 13) Both trials will be timed (to be used as the tiebreaker only). Times will be recorded, at a minimum, to the nearest hundredth second. The timing of the flight ends when any part of the glider comes in contact with any object (first-touch point). In case of a tie, the longest flight duration (hang-time) will be used as a tiebreaker.

SCORING:

- 1) Performance Points (**best of two launches**)
 - a. Winning Performance (P_w) = team with the best distance from all teams in the same Division/Grade Level (receives 75 points)
 - b. Team Performance (P_t) = team's best distance out of two launches
 - c. Team Performance Ratio = P_t divided by P_w
 - d. Team Performance Points = $P_t / P_w \times 75$
- 2) Final Team Score = (Team Performance Points - Penalties) + Engineering Lab Book Points
 - a. Since the glider penalties (see General Rules 1 and 2) will be **subtracted** from the performance points, the following will serve as an example of how judges will factor in penalties on MESA Day.

Team # 1 had a best overall distance of 15m and did not receive a penalty. They scored 25 points for the Lab Book.

Best Team Distance = 15m

Best Overall Distance = 15m

Performance Points = $15/15 = 1$; $1 \times 75 = 75$ points

Penalties = None

Poster = 25 Points

Final Score = Performance Points - Penalties + Lab Book = $75 - 0 + 25 = 100$

Team # 2 has a best team distance of 10m, their glider is not properly labeled, and scored 15 points on the lab book

Best Team Distance = 10m

Best Overall Distance = 15m

Performance Points = $10/15 = .6667 \times 75 = 50$ points

Penalties = (10% for improper labeling) $10\% \times 50 = 5$

Poster = 15 Points

Final Score = Performance Points - Penalties + Lab Book = $50 - 5 + 15 = 60$ Points

- 3) **Tie Breaker:** if there is a tie among Final Scores, the glider with the longest flight time on the corresponding best launch will be the winner.

AWARDS:

- Medals will be awarded for 1st, 2nd, and 3rd place based on the Final Score.
- Ribbons will be awarded for 4th, 5th, and 6th place based on Final Score.

ATTACHMENTS/APPENDIX:

- A: Mathematical Concepts
- B: Official Rubber Launcher Mechanism Specifications
- C: Obstacle Specification
- D: Course Layout
- E: Inspection and Score Sheet for Glider

A. Mathematical Concepts

Use of mathematical concepts/equations: MESA has provided a set of equations to help you along the way. While these equations are not mandatory to use, they should provide a roadmap to completing the math concepts.

1. $Lift Equations = Lift Coefficient \times \frac{Air Density \times Velocity Squared}{2} \times Wing Area$

2. $Aspect Ratio = \frac{Wing Length}{Wing Width}$

Applicable Math Concept/Equation (state concept/equation): Calculating Power
--

The lift coefficient can be calculated by multiplying the angle of attack (in this case 0.087(in radians) thanks to the launcher) by 2pi (3.14159); so, the lift coefficient is 0.547. The standard air density is 1.225 kg/m³. The velocity is calculated by dividing the distance traveled in the time it takes your glider to travel that far. All this is multiplied by the wing area. Wing area will vary based on shape. Please follow this [link](#) to use the appropriate formula.

Example: The wings on your glider are rectangular with a length of 3 meters and a width of 2 meters. Calculate the lift of your glider if it traveled 7 meters in 6 seconds.

$$Lift Coefficient \times \frac{Air Density \times Velocity Squared}{2} \times Wing Area$$

$$Lift = (0.547) \times \frac{1.225(kg/ms^3) \times \left(\frac{7 \text{ meters}}{6 \text{ second}}\right)^2}{2} \times (3 \text{ meters} \times 2 \text{ meters})$$

$$Lift = (0.547) \times \frac{1.22kg/m^3 \times \frac{49m^2}{36s^2}}{2} \times 6m^2$$

$$Lift = 0.547 \times \left(\frac{1.667 kg/ms^2}{2}\right) \times 6m^2$$

$$Lift = 0.547 \times (0.834 kg/ms^2) \times 6m^2$$

$$Lift = 2.737 kg \frac{m}{s^2}$$

Applicable Math Concept/equation (state concept/equation): Calculating Aspect Ratio

An Aspect Ratio (AR) is written as follows 3:2. To calculate aspect ratio, simply measure the wing length and wing width. Afterwards, divide the length by the width.

$$\text{Aspect Ratio} = \frac{\text{Wing Length}}{\text{Wing Width}}$$

Example: If your wing width is 3 meters and your wing length is 27 meters after measuring, what is your glider's Aspect Ratio?

$$\text{Aspect Ratio} = \frac{\text{Wing Length}}{\text{Wing Width}}$$

$$AR = \frac{27 \text{ meters}}{3 \text{ meters}} \rightarrow AR = \frac{9 \text{ meters}}{1 \text{ meters}} \rightarrow AR = 9:1$$

B – OFFICIAL LAUNCHER MECHANISM SPECIFICATIONS

1. The only power source allowed for the glider to use is the rubber band provided by the host MESA center.
2. The official launcher mechanism consists of a folding table, a rubber band, and a set (2) of low profile clamps.
 - a. The [COSCO folding table](#) or equivalent has a size of 74.93 cm (29.50 inches) width, 147 cm (72 inches) in length and 73.99 cm (29.13 inches). The folding table is angled at 0 degrees.
 - b. The rubber band is a 1/4" Wide x 80" Circumference x 1/16" Thickness. It is available from McMaster-Carr, currently listed on <https://www.mcmaster.com/8848T96/> as part number 8848T96. The Rubber Band will be replaced after the 16th launch. Its final position will be up to the competitors discretion.
 - c. A set of low profile clamps (<https://www.mcmaster.com/1705A11/>) will be used to secure the rubber bands together. The clamps will be 60.96 cm (24 inches) apart from each other and placed towards the front of the folding table. The rubber band will be looped around.
 - d. A 3D printed model will be used as an adapter. ([Link](#)) (OPTIONAL)

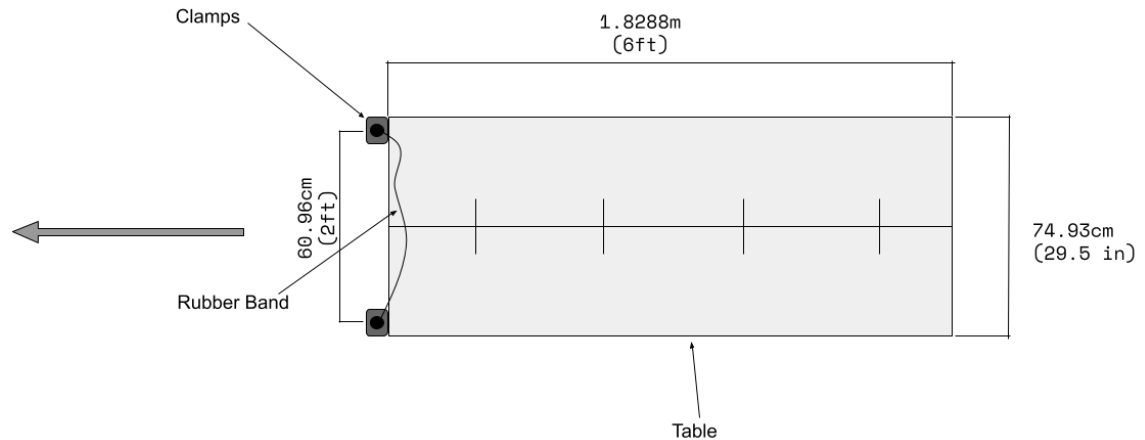

C - OBSTACLE SPECIFICATION

1. The obstacle measurements are 152.40 cm (60in) in height and 3.048 m (10ft) in width.
2. The obstacle is constructed by two 152.40 cm (60in) PVC pipes, string and a pair of fish-eye screws.
3. Nylon String was used to connect both PVC Pipes.
4. 5ft will be measured from the middle of the Nylon string.

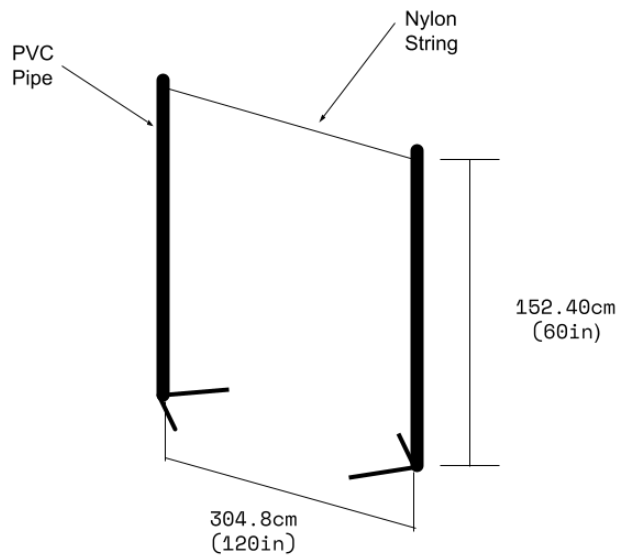

D - COURSE LAYOUT

1. The layout of the competition is shown in the diagram below.
2. The distance from the edge of the table to the obstacle is 518.60cm (204in).

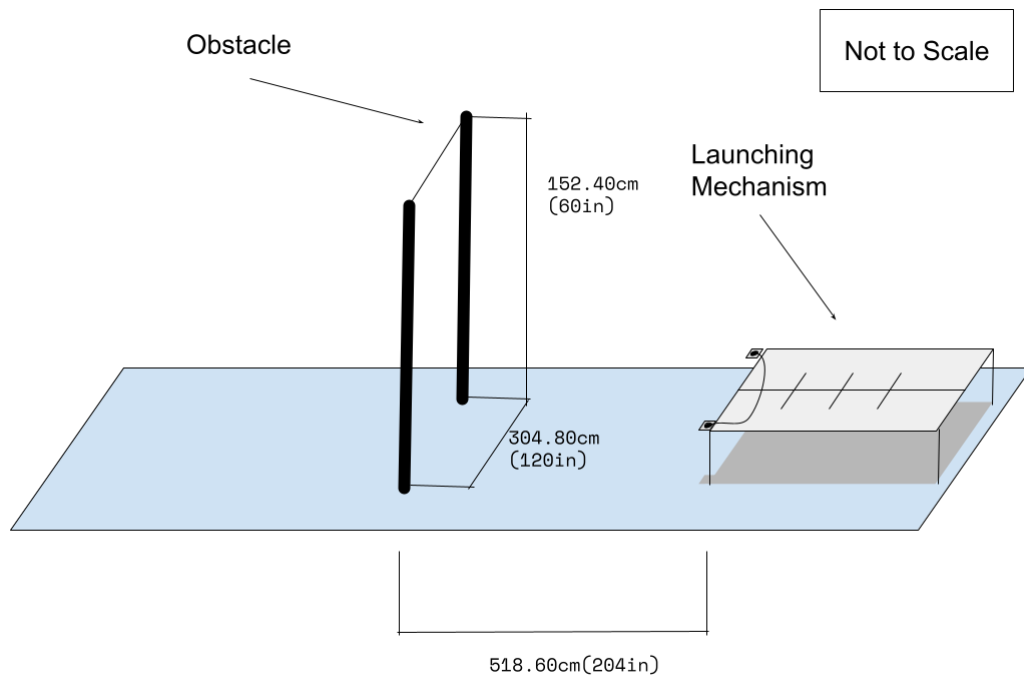

E: INSPECTION AND SCORE SHEET FOR GLIDER

Middle School – Grade 6 and Grades 7/8

Copies of this inspection and score sheet will be provided by the MESA Day Host Center.

Student Names: _____ Grade: 6 or 7/8 (circle one)

School: _____ MESA Center: _____

Specification Checklist:	Yes	No
Are the contestants' names, grade, school name, and center clearly visible on the glider? (if information is provided on a tie-on label—student MUST launch glider with label attached.) - General Rule #1		10% Penalty
Does the glider contain a feature that adapts to the launcher adapter or rubber band that is easily identifiable? - General Rule #2		10% Penalty
Does the glider have the correct amount of ping pong balls (payload)?		DQ
Is the glider capable of self-sustained flight without links to the ground for lift, propulsion or guidance? -General Rule #6		DQ
Glider has an easily identifiable fuselage, wing, and tail? General Rule #10		DQ
Does the glider use remote controls? General Rule #11	DQ	
Will stored energy be used after the initial launch? (thrust, motors, batteries, etc.) - General Rule #12	DQ	
Overall Specification Check	Pass	Fail

Performance:

Measure to the nearest 2cm (.75in)

Distance (Glider's 1st Touch-point w/ ground or other obstruction):	Does the Glider have the correct amount of Payload? (2 ping pong balls)	If the launch is disqualified, considered a Mistrial or none please indicate it below:
1st Launch:	Yes / No	Disqualified / Mistrial / None
2nd Launch:	Yes / No	Disqualified / Mistrial / None

Reasons for Glider Disqualification(s):	Reasons for Launch Mistrial:
Missing Ping Pong balls. (See General Rule #3)	Glider part(s) break-off during flight
The glider must be capable of being launched by the official launcher and must have an identifiable fuselage, wing, and tail. (See General Rule #10)	Glider goes outside the boundary of the obstacle

Hang Time (needed for tiebreaker)
1st Launch Flight Time:
2nd Launch Flight Time:

Best TEAM Distance _____
 Best OVERALL Distance _____ (from same division/grade level)
 Performance Ratio (TEAM / OVERALL) = _____
 Performance Ratio x 75 = _____ Performance Points
 Glider Penalties (0, 10% or 20%) = _____
 Performance Points - Glider Penalties=

FINAL SCORE

Poster Rubric

Category	Excellent (3 points)	Met Criteria (2 points)	Poor (1 point)	Not Present (0 points)
Project Overview - team summarizes the project, including team objective(s), successes, challenges, and performance expectation				
Glider Graphic – Team has a graphic of their robot				
Cargo Hold – Team has a graphic demonstrating how they will stow the cargo in the glider.				
Testing Data 1 – Team has a graphic of testing data that helped determine their design decisions				
Testing Data 2 – Team has a 2 nd graphic of testing data that helped determine their design decisions				
Glider Name			Yes	No
School & Team Member Names			Yes	No
School Logo			Yes	No
MESA Logo			Yes	No
Column Totals				